

NO	DESCRIPTION	MAT'L	Q'TY	WT(kg)	REMARKS

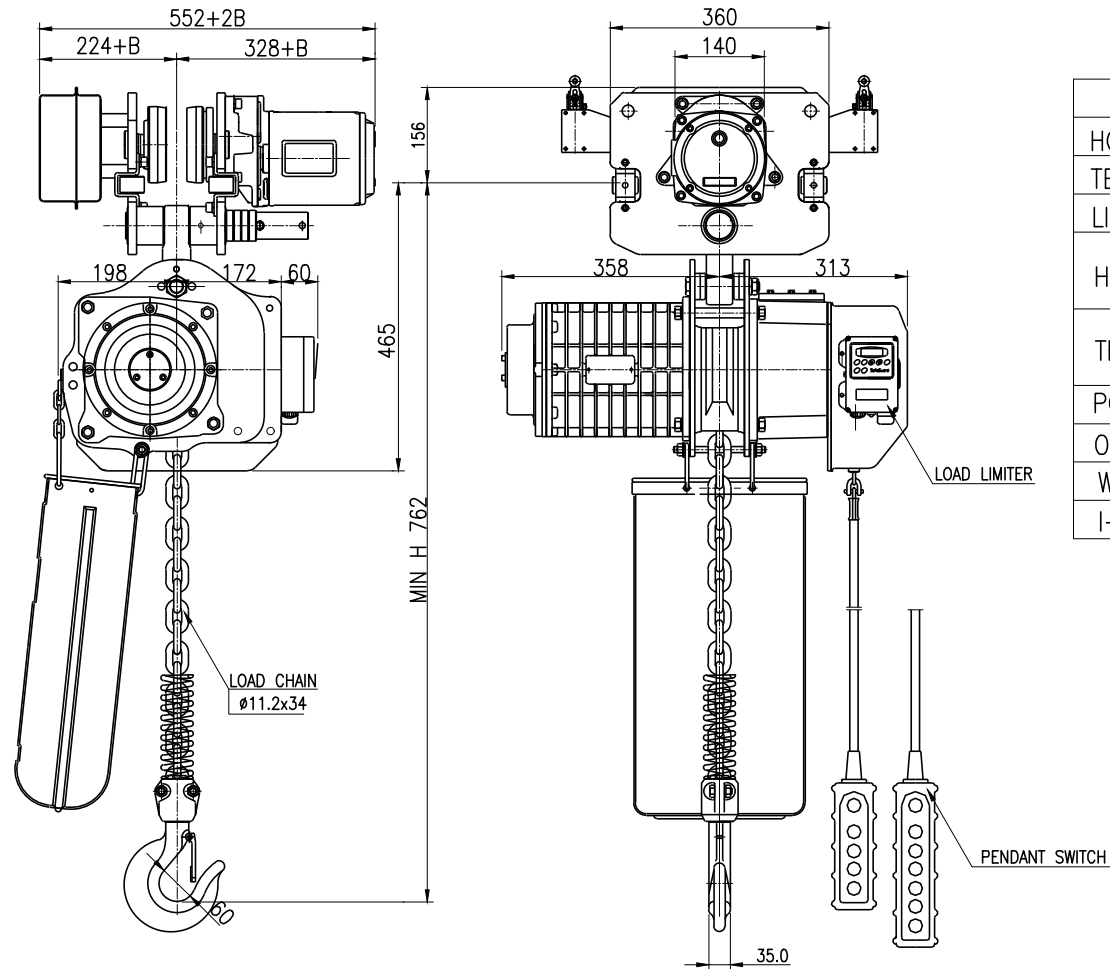

SPECIFICATION			
HOISTING LOAD	2.5	TON	
TESTING LOAD	3.125	TON	
LIFTING HEIGHT	5	M	
HOISTING	SPEED	50/60Hz	5.4/6.5 M/MIN
	MOTOR	3.5 KW x 4P x 1 SET	
TRAVERSING	SPEED	50/60Hz	11/14 M/MIN
	MOTOR	0.75KW x 6P x 1 SET	
POWER SUPPLY	AC 220,380,440. x 3ø x 60 Hz		
OPERATING METHOD	P.B type ON . FL		
WEIGHT	201 KG		
I-BEAM SIZE	100-150 MM		

NOTE

- * B 는 BEAM 변동 치수임.
- * ROLLER DIA : ø125
- * LIMIT SWITCH : OPTION
- * 본 도면은 I-BEAM 100MM 기준임.

TITLE DSM-2.5S CHAIN HOIST				PROJECTION	
WORK NO		WORK NAME			
				SCALE	Q'TY
				1/1	1
DRAWN	CHECKED	REVIEWED	APPROVED	DRAWING NO	
H.J		LEE	Y. K	DSM25S001	
2020.09.14		2020.09.14	2020.09.14		

도면에 지시되지 않은 일반공차						
가공법	치수	3-6	6-30	30-120	120-315	315-1000
선	삭					
구멍간	거리	±0.1	±0.2	±0.3	±0.5	±0.8

REV.NO	DATE	REVISION DESCRIPTION	DRAWN	CHECKED	APPROVED

DAESAN InoTEC INC